

Hypertherm[®]

**Centricut[®] plasma torches
and consumables for
Whitney[®]**

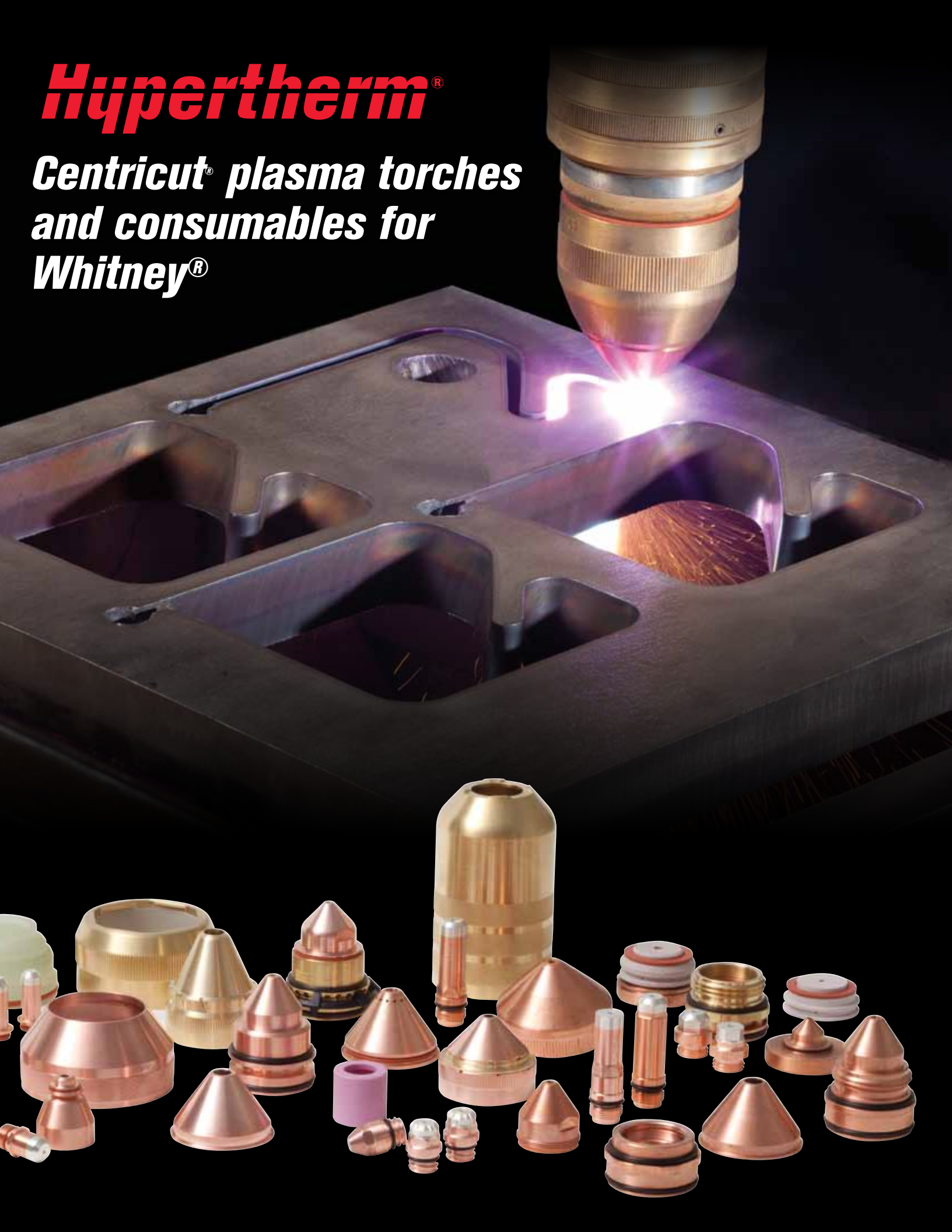

Product is available for the following major OEM brands

AMADA®

ESAB®

KALIBURN®

KJELLBERG®

KOIKE®

KOMATSU®

LINCOLN®

THERMAL

DYNAMICS®

WHITNEY®

WIEDEMANN®

OEM Whitney®

System OW250®

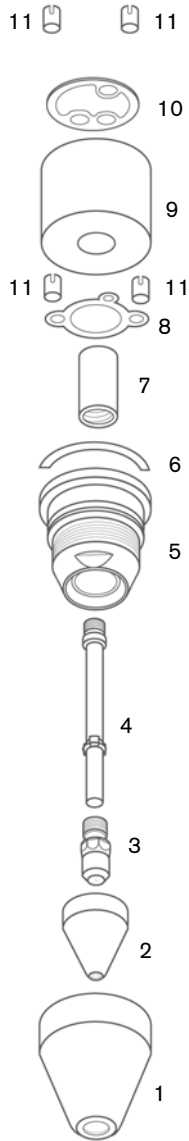

Consumables

Centricut part number	Reference number	Description	Pkg qty
1 C14-332	648-332	Nose piece	1
2 C14-330	648-330	Nozzle, Air, 063, 150 amp	5
C14-331-S	648-331	Nozzle, Air, .098	5
C14-731	N/A	Nozzle, Air, .110	5
3 C14-328	648-328	Electrode, low amp, Air, 150 amp	5
C14-327	648-327	Electrode, Air, with o-ring C14-010, 250 amp	5
C14-927	648-327	Electrode, Air, without o-ring, 250 amp	5

Maintenance items

Centricut part number	Reference number	Description	Pkg qty
4 C14-326	648-326	Cooling tube	1
5 C14-280	648-280	Nozzle holder	1
6 C14-282	648-282	Gasket spacers	2
7 C14-281	648-281	Gas guide ring	1
8 C14-286	648-286	Lower gasket	5
9 C14-287	648-287	Insulating spacer	1
10 C14-288	648-288	Middle gasket	5
11 C14-285	648-285	Hole guides	5
C14-010	N/A	O-ring	5
C14-283	648-283	O-ring	5
C14-284	648-284	O-ring	5
C14-793	649-793	O-ring seal	4
027055	N/A	Lubricant .25 oz. (7 ml) tube	1

OEM Whitney®

System IC300®

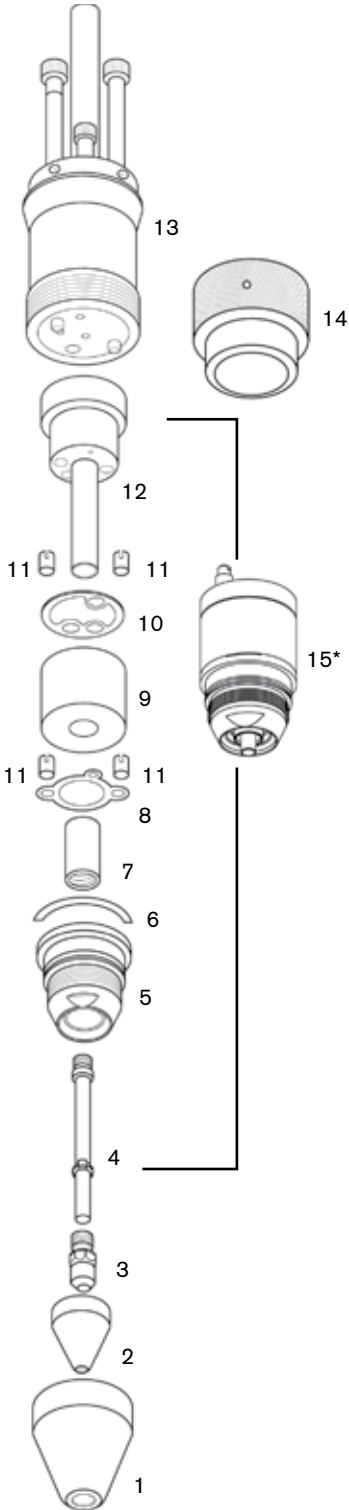

Consumables

Centricut part number	Reference number	Description	Pkg qty
1 C14-332	648-332	Nose piece	1
2 C14-330	648-330	Nozzle, Air, .063, 150 amp	5
C14-331-S	648-331	Nozzle, Air, .098	5
C14-731	N/A	Nozzle, Air, .110	5
3 C14-328	648-328	Electrode, low amp, Air, 150 amp	5
C14-327	648-327	Electrode, Air, with o-ring C14-010, 250 amp	5
C14-927	648-327	Electrode, Air, without o-ring, 250 amp	5

Maintenance items

Centricut part number	Reference number	Description	Pkg qty
4 C14-794	649-794	Cooling tube	1
5 C14-280	648-280	Nozzle holder	1
6 C14-282	648-282	Gasket spacers	2
7 C14-281	648-281	Gas guide ring	1
8 C14-286	648-286	Lower gasket	5
9 C14-959	649-959	Insulating spacer	1
10 C14-288	648-288	Middle gasket	5
11 C14-285	648-285	Hole guides	5
12 C14-960	649-960	Manifold	1
C14-793	649-793	O-ring seal	4
13 C14-964	649-964	Upper body	1
C14-962	649-962	High frequency socket	1
C14-963	649-963	High frequency pin	1
14 C14-961	649-961	Head cover assembly	1
C14-866	649-966	Torch tube cover	1
C14-765	649-765	IC300 one touch torch	1
15 C14-118*	N/A	Lower body assembly (includes items 4 – 12)	1
C14-010	N/A	O-ring	5
C14-283	648-283	O-ring	5
C14-284	648-284	O-ring	5
027055	N/A	Lubricant .25 oz. (7 ml) tube	1

* Centricut part features a unique Hypertherm design that differs from the OEM design.

OEM Whitney®

System TRUECUT®

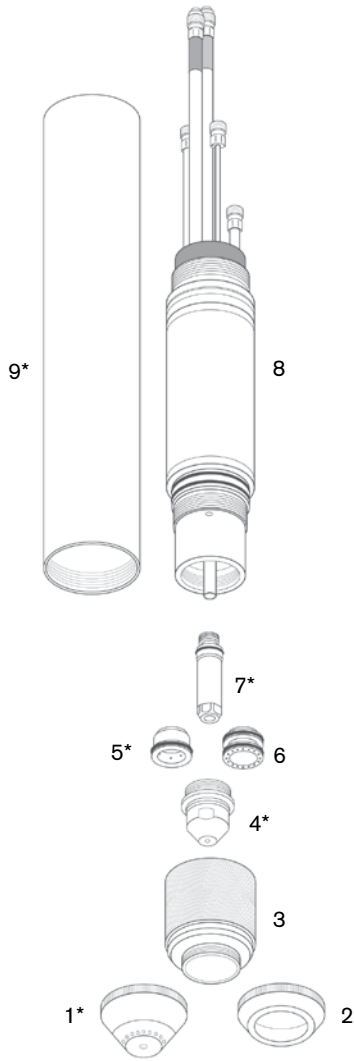

Consumables

Centricut part number	Reference number	Description	Pkg qty
1 020424	631-452	Shield, machine, Air, O ₂ , N ₂ , 200 amp	1
C32-924*	N/A	Shield, machine, Air, O ₂ , N ₂ , 200 amp	1
020448	631-453	Shield, Air, N ₂ , ArH ₂ , 100 amp	1
2 020668	631-454	Shield, machine, Air, 40 amp	1
3 020423	631-455	Retaining cap	1
4 C32-608	631-456	Nozzle, Air, .086, N ₂ , ArH ₂ , 200 amp	1
C32-611*	631-457	Nozzle, Air, .059, N ₂ , ArH ₂ , 100 amp	1
C32-689*	631-458	Nozzle, Air, .038, 40 amp	5
C32-605	631-459	Nozzle, O ₂ , .082, 200 amp	1
C32-690	632-459	Nozzle, O ₂ , .055, 100 amp	1
5 C32-907*	N/A	Swirl ring, Air, N ₂ , ArH ₂ , 100/200 amp	1
020613	631-462	Swirl ring, Air, 40 amp, and O ₂ , 100 amp	1
020679	632-455	Swirl ring, Air, 200 amp	1
6 020-678	632-456	Swirl ring, O ₂ , 200 amp	1
7 C32-664*	632-457	Electrode, O ₂ , 200 amp	1
C32-1021*	220021	SilverLine® electrode, O ₂ , 200 amp	1
C32-415	632-458	Electrode, N ₂ , ArH ₂	5
C32-547	633-706	Electrode, Air, O ₂ , 100 amp	5

Maintenance items

Centricut part number	Reference number	Description	Pkg qty
8 120584	632-599	Torch body, 180°	1
C32-027	632-597	O-ring	5
020963	632-870	Water tube	1
9 C32-431*	N/A	Double threaded mounting tube	1
027055	N/A	Lubricant .25 oz. (7 ml) tube	1

* Centricut part features a unique Hypertherm design that differs from the OEM design.



**Technology products for ESAB[®],
Kjellberg[®] and Kaliburn[®]**

Hypertherm[®]

Cut with confidence[™]

Hypertherm, Inc.
Hanover, NH 03755 USA
603-643-3441 Tel

Hypertherm (S) Pte Ltd.
Singapore 349567
65 6841 2489 Tel

**Hypertherm (Shanghai)
Trading Co., Ltd.**
PR China 200052
86-21 5258 3330 /1 Tel

Hypertherm Europe B.V.
4704 SE Roosendaal, Nederland
31 165 596907 Tel

HYPERTHERM BRASIL LTDA.
Guarulhos, SP - Brasil
55 11 2409 2636 Tel

www.hypertherm.com



Hypertherm and Centricut are registered trademarks of Hypertherm, Inc. and may be registered in the United States and/or other countries. All other trademarks are the properties of their respective owners.