

Hypertherm[®]

***Centricut[®] plasma torches
and consumables for
Thermal Dynamics[®]***



Product is available for the following major OEM brands

AMADA®

ESAB®

KALIBURN®

KJELLBERG®

KOIKE®

KOMATSU®

LINCOLN®

THERMAL

DYNAMICS®

WHITNEY®

WIEDEMANN®

PCH-20®

OEM Thermal Dynamics® System Dynapak 110®, PAK® 2XT™

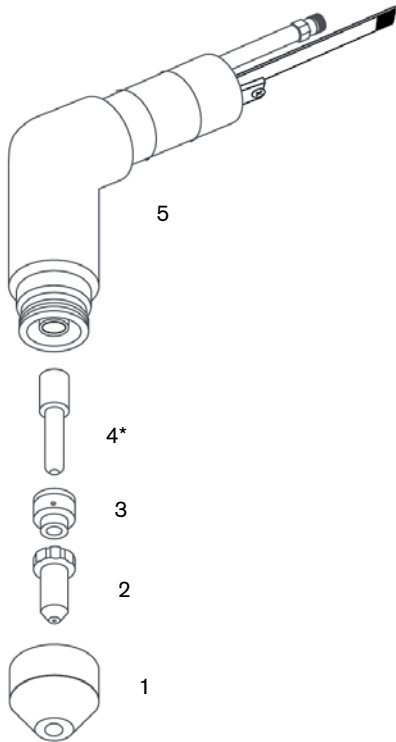

Consumables

Centricut part number	Reference number	Description	Pkg qty
1 C21-214	8-3214	Shield cup	5
2 C21-218	8-3218	Tip, .031	5
3 C28-233	8-3233	Gas distributor	1
4 C42-006*	9-6006	Electrode	5
C02-016	8-0531	O-ring	5

Maintenance items

Centricut part number	Reference number	Description	Pkg qty
5 T21-220	8-3220	PCH-20 torch body, 70°	1
027055	N/A	Lubricant .25 oz. (7 ml) tube	1

* Centricut part features a unique Hypertherm design that differs from the OEM design.

PCH/M-30®

OEM Thermal Dynamics® System PAK3®

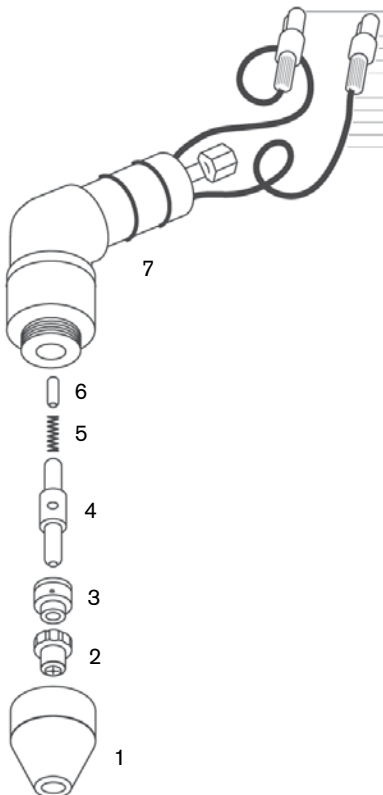

Consumables

Centricut part number	Reference number	Description	Pkg qty
1 T28-500	9-5500	Shield cup	10
2 C28-501	9-5501	Tip, .040	10
3 C28-233	8-3233	Gas distributor	1
4 C28-503	9-5503	Electrode	10
5 T28-505	9-5505	Spring	5
6 T28-504	9-5504	Continuity pin	5

Maintenance items

Centricut part number	Reference number	Description	Pkg qty
T28-509	9-5509	PCM-30 torch body, 180°	1
7 T28-512	9-5512	PCH-30 torch body, 70°	1
027055	N/A	Lubricant .25 oz. (7 ml) tube	1

Centricut is a registered trademark of Hypertherm, Inc. and may be registered in the United States and/or other countries. All other trademarks are the properties of their respective owners. Centricut is in no way affiliated with Thermal Dynamics.

PCH/M-10/25®

OEM Thermal Dynamics® System PAK Master® 25, Econo PAK® 25, Drag Gun

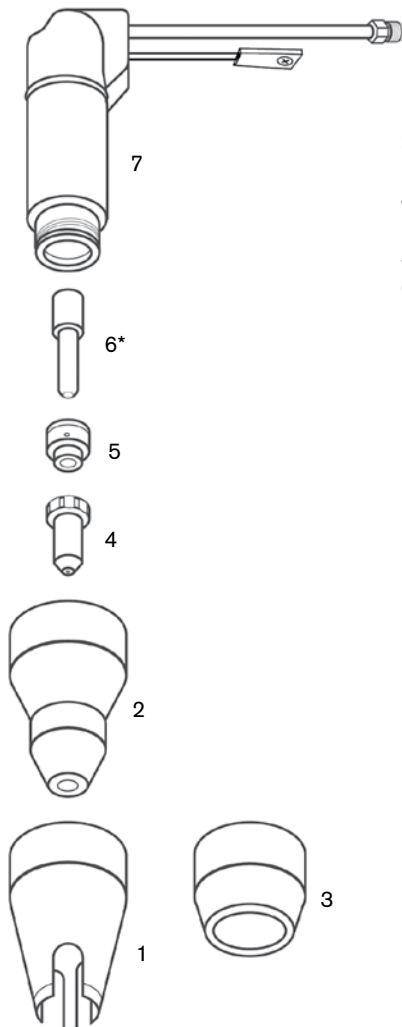

Consumables

Centricut part number	Reference number	Description	Pkg qty
1 C42-004	9-6004	Crown cup, copper	1
2 C42-003	9-6003	Shield cup	1
T42-503	9-6503	Shield cup, extended life, use with C42-003	1
4 C42-476	9-4476	Tip, drag cut, .026, 20 amp	5
T42-099	9-6099	Tip, drag cut, .026, 12 amp	10
5 C42-007	9-6007	Gas distributor	1
6 C42-006*	9-6006	Electrode	5

Maintenance items

Centricut part number	Reference number	Description	Pkg qty
7 T42-807	9-5807	PCH-25/35 torch body, 70°	1
T42-808	9-5808	PCH-25/35 torch body, 90°	1
T42-016	9-0016	PCH-10 torch body, 70°	1
027055	N/A	Lubricant .25 oz. (7 ml) tube	1

* Centricut part features a unique Hypertherm design that differs from the OEM design.

PCH/M-26/28/35/38®

OEM Thermal Dynamics® System STAK PAK® 35, PAK MASTER® 50, 38XL, ECONO PAK® 50

Consumables

Centricut part number	Reference number	Description	Pkg qty
1 C42-004	9-6004	Crown cup, copper, use with C42-003	1
2 C42-003	9-6003	Shield cup	1
3 T42-503	9-6503	Shield cup, extended life, use with C42-003	1
4 C42-001	9-6001	Tip, drag cut, .031, 35 amp	5
C42-501	9-6501	Tip, drag cut, extended life, .031, 35 amp	5
C42-476	9-4476	Tip, drag cut, .026, 20 amp	5
C42-000	9-6000	Tip, standoff, .031, 35 amp	10
C42-500	9-6500	Tip, standoff, extended life, .031, 35 amp	10
5 C42-007	9-6007	Gas distributor	1
C42-507	9-6507	Gas distributor, extended life	1
6 C42-006*	9-6006	Electrode	5
C42-506*	9-6506	Electrode, extended life	5

Maintenance items

Centricut part number	Reference number	Description	Pkg qty
7 T42-807	9-5807	PCH-25/35 torch body, 70°	1
T42-808	9-5808	PCH-25/35 torch body, 90°	1
T42-809	9-5809	PCM-35 torch body, 180°	1
027055	N/A	Lubricant .25 oz. (7 ml) tube	1

* Centricut part features a unique Hypertherm design that differs from the OEM design.

OEM Thermal Dynamics® System PAK®5

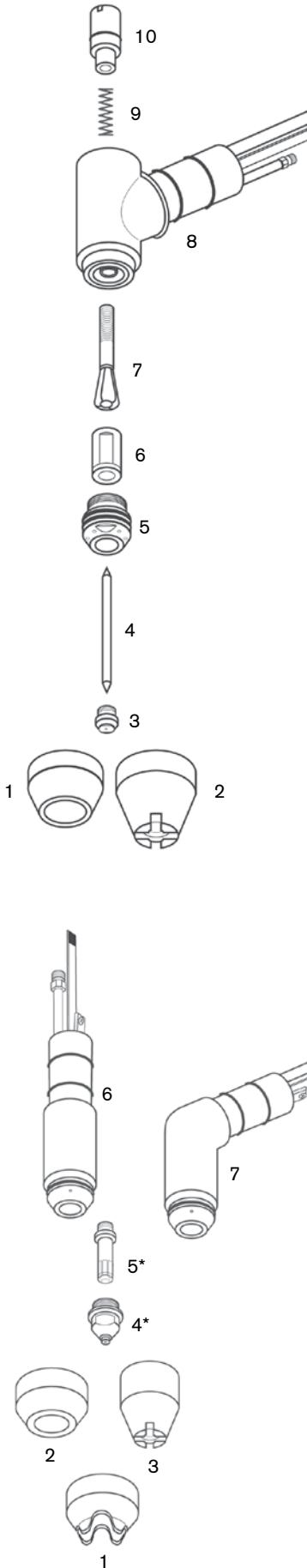

Consumables

Centricut part number	Reference number	Description	Pkg qty
1 T29-505	8-5505	Shield cup	5
2 T29-519	8-5519	Crown cup	5
3 T29-507	8-5507	Tip, .046	10
4 C29-508	8-5508	Electrode	5
5 T29-520	8-5520	Liner	1
6 T29-510	8-5510	Sleeve	1
7 T29-506	8-5506	Collet	5

Maintenance items

Centricut part number	Reference number	Description	Pkg qty
T29-504	8-5504	O-ring, torch body	5
8 T29-501	8-5501	PCH-50 torch body	1
9 T29-503	8-5503	Spring	5
10 T29-502	8-5502	Collet release button	1
027055	N/A	Lubricant .25 oz. (7 ml) tube	1

PCH/M-51®

OEM Thermal Dynamics® System PAK® 3XR™, 5XR™, 5Xt™, 6XR™, 625XR™, 750XR™, Dynapak 4Xi, 6Xi

Consumables

Centricut part number	Reference number	Description	Pkg qty
1 T06-779	9-5779	Crown cup, copper long, use with C06-781	1
C07-780	9-5780	Crown cup, copper short, use with C07-781	1
2 C06-630	9-5630	Shield cup, ceramic	5
3 C06-526	8-5526	Crown cup, ceramic	5
C06-781	8-2159	Shield cup, shatter proof	5
4 C06-631*	9-5631	Tip, chrome, .043, 55 amp	10
C06-031*	N/A	Tip, copper, .043, 55 amp	10
C06-718*	9-5718	Tip, chrome, .038, 35 amp	5
C06-321	8-3321	Tip, chrome, .047, 70 amp	5
C06-724	9-5724	Tip, chrome, gouging, .078	5
5 C06-633*	9-5633	Electrode, chrome	10
C06-033*	N/A	Electrode, copper	10

Maintenance items

Centricut part number	Reference number	Description	Pkg qty
6 C06-634	9-5634	PCM-51 torch body	1
7 C06-635	9-5635	PCH-51 torch body, 70°	1
C06-901	N/A	Bottoming tap, 7/16 in – 28, tip	1
C06-902	N/A	Bottoming tap, 1/4 in – 28, electrode	1
C06-525	8-5525	O-ring	5
C08-010	N/A	Ball casters	5
027055	N/A	Lubricant .25 oz. (7 ml) tube	1

* Centricut part features a unique Hypertherm design that differs from the OEM design.

OEM Thermal Dynamics[®] System PAK[®] 5XR[™], 6XR[™], 7XR[™], 8XR[™], 10XR[™], 625XR[™], 750XR[™], 1000XR[™], 1250XR[™]

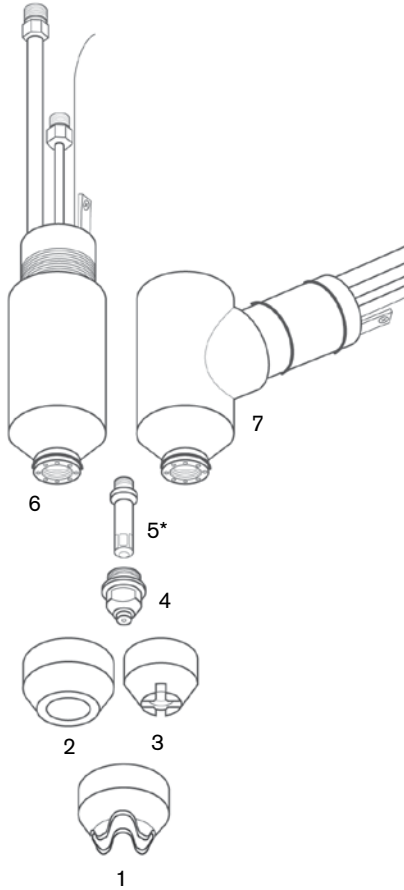

Consumables

Centricut part number	Reference number	Description	Pkg qty
1 T06-779	9-5779	Crown cup, copper long, use with C06-781	1
C07-780	9-5780	Crown cup, copper short, use with C07-781	1
3 C07-694	9-5694	Crown cup, ceramic	5
2 C07-717	N/A	Shield cup, short	10
C07-617	9-5617	Shield cup, long	5
C07-781	9-5781	Shield cup, shatter proof	5
4 C07-702	9-5702	Tip, .035, 35 amp	10
C07-618	9-5618	Tip, .043, 55 amp	10
C07-707	9-5707	Tip, .047, 70 amp	10
T07-782	9-5782	Tip, .052, 80 amp	5
C07-708	9-5708	Tip, .059, 105 amp	10
C07-908	N/A	Tip, .059, 105 amp, chrome	10
T07-710	9-5710	Tip, .093	10
5 C07-331*	8-3331	Electrode, Air, copper	10
C07-619	9-5619	Electrode, Air, chrome	10
T07-711	9-5711	Electrode, N ₂	5
C07-931	N/A	Electrode	10

Maintenance items

Centricut part number	Reference number	Description	Pkg qty
6 C07-643	9-5643	PCM-52 torch body	1
7 C07-642	9-5642	PCH-52 torch body, 70°	1
C06-525	8-5525	O-ring	5
C08-010	N/A	Ball casters	5
C07-901	N/A	Bottoming tap 1/2 – 20, tip	1
C07-902	N/A	Bottoming tap 7mm x 1, electrode	1
T07-007	8-4007	Wrench, tip	1
T07-620	9-5620	Wrench, electrode	1
027055	N/A	Lubricant .25 oz. (7 ml) tube	1

* Centricut part features a unique Hypertherm design that differs from the OEM design.

OEM Thermal Dynamics[®] System PAK MASTER[®] 100

Consumables

Centricut part number	Reference number	Description	Pkg qty
1 T06-779	9-5779	Crown cup, copper long, use with C06-781	1
C07-780	9-5780	Crown cup, copper short, use with C07-781	1
2 C07-717	N/A	Shield cup, short	10
C07-617	9-5617	Shield cup, long	5
C07-781	9-5781	Shield cup, shatter proof	5
3 C07-694	9-5694	Crown cup, ceramic	5
4 C07-702	9-5702	Tip, .035, 35 amp	10
C07-618	9-5618	Tip, .043, 55 amp	10
C07-707	9-5897	Tip, .047, 70 amp	10
T07-782	9-5782	Tip, .052, 80 amp	1
C07-708	9-5708	Tip, .059, 105 amp	10
C07-908	N/A	Tip, .059, chrome	10
T07-710	9-5710	Tip, .093	10
5 C07-331*	9-5898	Electrode, Air, copper	10

Maintenance items

Centricut part number	Reference number	Description	Pkg qty
6 T49-180	9-6180	PCM-53 torch body, 180°	1
7 T49-170	9-6170	PCH-53 torch body, 70°	1
T49-190	9-6190	PCH-53 torch body, 90°	1
C06-525	8-5525	O-ring	5
C08-010	N/A	Ball casters	5
C07-901	N/A	Bottoming tap 1/2 in. – 20, tip	1
C07-902	N/A	Bottoming tap 7mm x 1, electrode	1
T07-007	8-4007	Wrench, tip	1
T07-620	9-5620	Wrench, electrode	1
027055	N/A	Lubricant .25 oz. (7 ml) tube	1

* Centricut part features a unique Hypertherm design that differs from the OEM design.

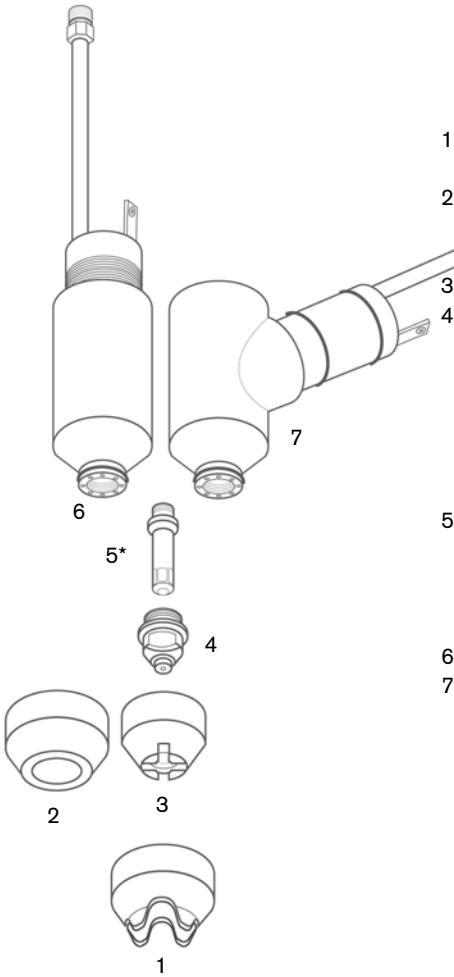

OEM Thermal Dynamics® System STAK PAK®

Consumables

Centricut part number	Reference number	Description	Pkg qty
1 T43-016	9-6016	Shield cup	1
2 T43-024	9-6024	Shield cup, long	1
C43-017	9-6017	Crown cup	1
3 C43-009	9-6009	Tip, Air, 70 amp	5
4 C43-022	9-6022	Gas distributor	1
5 C43-019*	9-6019	Electrode, Air	1

Maintenance items

Centricut part number	Reference number	Description	Pkg qty
6 T43-812	9-5812	PCM-70 torch body, 180°	1
7 T43-810	9-5810	PCH-70 torch body, 70°	1
027055	N/A	Lubricant .25 oz. (7 ml) tube	1

* Centricut part features a unique Hypertherm design that differs from the OEM design.

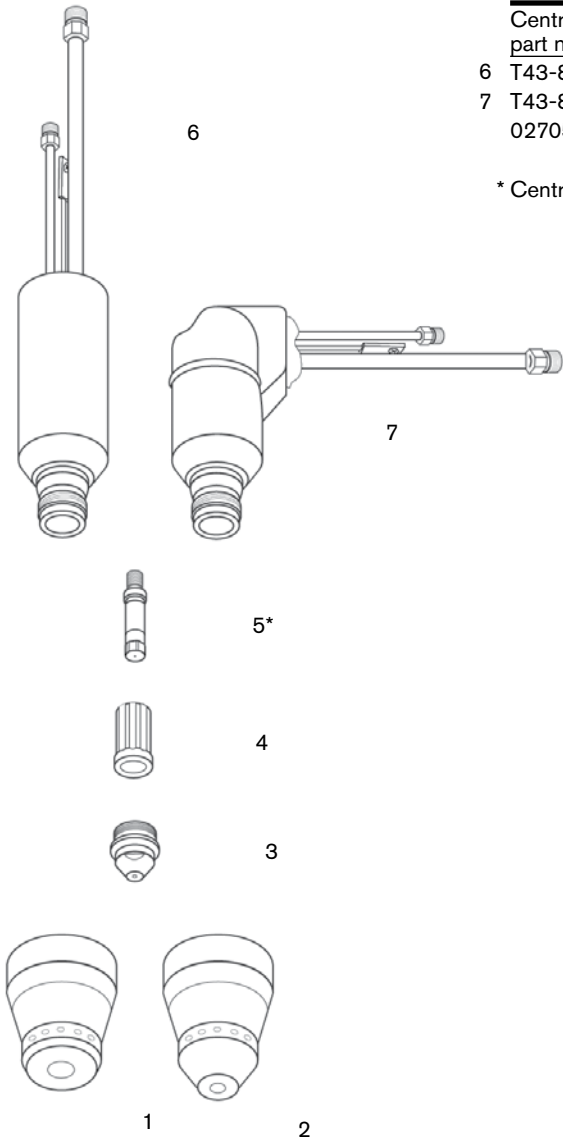

OEM Thermal Dynamics® System PAK® 22, 10, 5

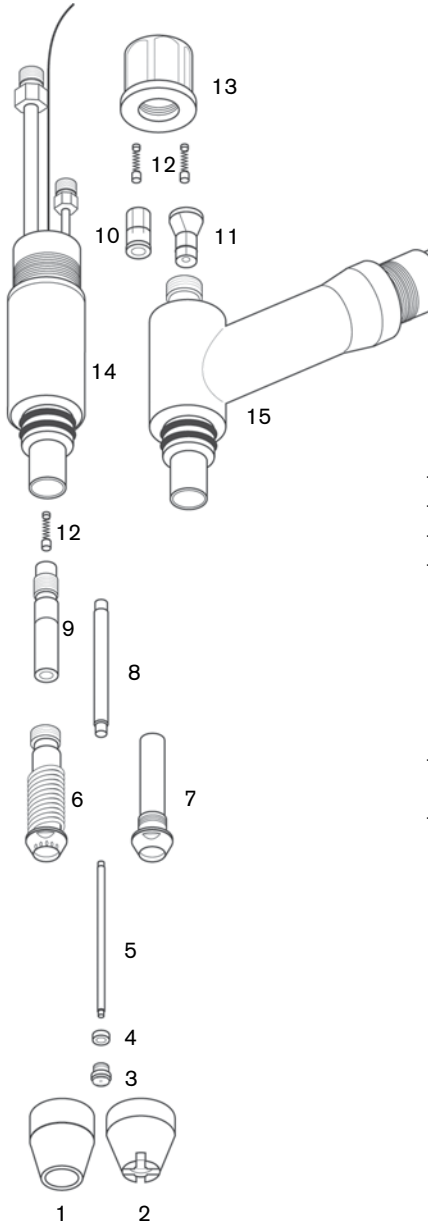

Consumables

Centricut part number	Reference number	Description	Pkg qty
1 C08-088	8-4088	Shield cup	5
2 T08-213	8-4213	Shield cup, crown	5
T08-045	8-4045	Shield cup, threaded 4A	1
3 C08-189	8-4189	Tip, .030	10
C08-211	8-4211	Tip, .046	10
C08-153	8-4153	Tip, .059, 100 amp	10
C08-170	8-4170	Tip, .070, ArH ₂ , 100 amp	10
4 C08-421	9-2421	Gas distributor	10
5 C08-073	8-4073	Electrode	5
6 C08-154	8-4154	Liner, 4B	1
7 T08-011	8-4011	Liner, 4A	1
8 C08-182	8-4182	Sleeve	1
9 T08-197	8-4197	Collet, 4BT	5
10 T08-156	8-4156	Collet, 4B	1
11 T08-049	8-4049	Collet, 4A	1
12 C08-050	8-4050	Spring assembly	5
13 T08-158	8-4158	Back cap	1
C08-069	8-4069	Gasket	5

Maintenance items

Centricut part number	Reference number	Description	Pkg qty
C08-010	N/A	Ball casters	5
14 T08-196	8-4196	PCM-4BT torch body	1
T08-161	8-4061	PCH-4B torch body, 90°	1
15 T08-160	8-4160	PCH-4B torch body, 70°	1
T08-901	9-1901	Insulating sleeve	1
027055	N/A	Lubricant .25 oz. (7 ml) tube	1

OEM Thermal Dynamics® System PAK® 44, 45

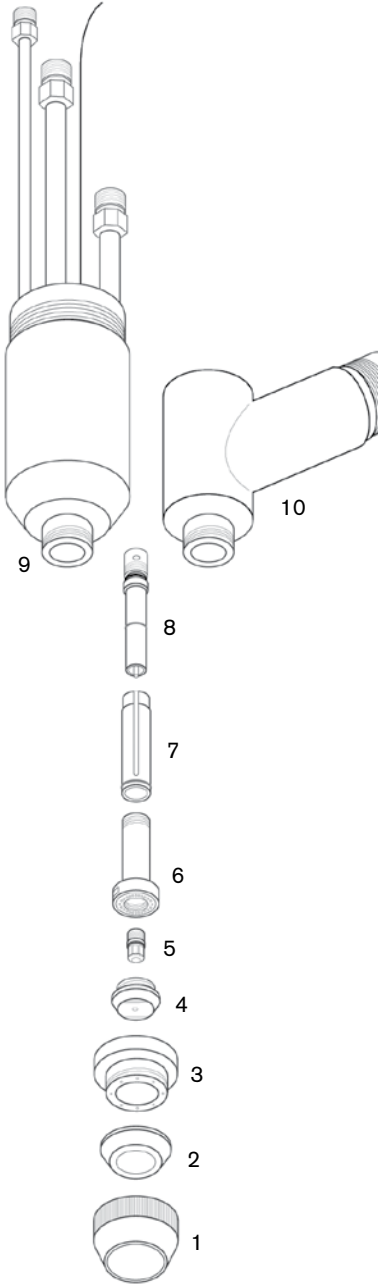

Consumables

Centricut part number	Reference number	Description	Pkg qty
1 C09-515	8-6515	End cap	1
2 C09-514	8-6514	End piece	5
3 C09-581	8-6581	Outer insulator	1
C09-512	8-6512	Gasket	5
4 C09-580	8-6580	Tip, .067, 100 amp	10
C09-648	8-6648	Tip, .076, 150 amp	10
C09-575	8-6575	Tip, .093, 200 amp	10
C09-582	8-6582	Tip, .113, 300 amp	10
C09-572	8-6572	Tip, .125, 400 amp	10
5 C09-578	8-6578	Electrode, general purpose	10
C09-586	8-6586	Electrode, low amp	10
6 C09-571	8-6571	Liner, includes o-rings C09-531 and C09-956	1
7 C09-569	8-6569	Gas distributor	1
T09-587	8-6587	Gas distributor, reverse swirl	1
T09-547	8-6547	Gas distributor	1
8 C09-615	8-6615	Electrode holder	1

Maintenance items

Centricut part number	Reference number	Description	Pkg qty
9 C09-577	8-6577	PCM-6B torch body, 180°	1
C09-584	8-6584	PCH-6B torch body, 90°	1
10 T09-583	8-6583	PCH-6B torch body, 70°	1
T09-614	8-6614	Heat shield, PCM-6B	1
027055	N/A	Lubricant .25 oz. (7 ml) tube	1

Note: Tips include o-rings C09-683 and C09-956

OEM Thermal Dynamics® System PAK® 10XR™

Consumables

Centricut part number	Reference number	Description	Pkg qty
1 C27-100	8-1100	Shield cup, hand	5
2 C27-345	9-4345	Shield cup, machine	5
3 C27-101	8-1101	Crown cup	5
4 C27-343	9-4343	Tip, .039, 35 amp	10
C27-342	9-4342	Tip, .047, 70 amp	10
C27-341	9-4341	Tip, .059, 105 amp	10
5 C27-340	9-4340	Electrode	10
6 C27-106	8-1106	Liner	1
7 C27-339	9-4339	Gas distributor	1
8 C27-108	8-1108	Electrode holder	1

Maintenance items

Centricut part number	Reference number	Description	Pkg qty
C27-111	N/A	Electrode wrench	
9 C27-112	8-1112	PCM-100 torch body	1
C27-113	8-1113	PCH-100 torch body, 70°	1
C27-556	8-0556	O-ring	5
C27-134	8-1134	O-ring, gas distributor	5
C27-152	8-1152	O-ring, electrode holder, large	5
C27-133	8-1133	O-ring, electrode holder, small	5
027055	N/A	Lubricant .25 oz. (7 ml) tube	1

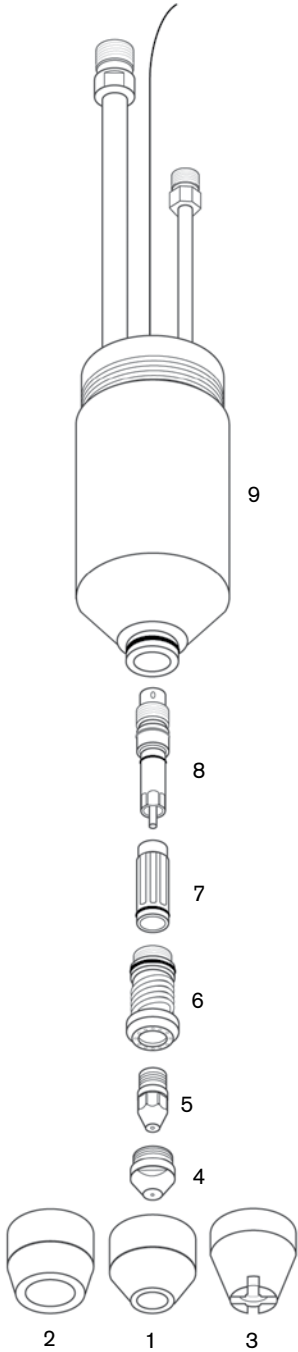

OEM Thermal Dynamics® System STAK PAK®

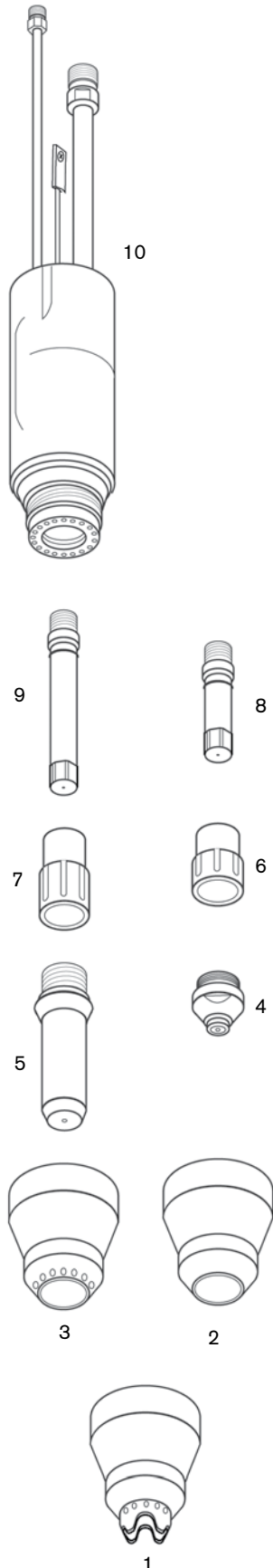

Consumables

Centricut part number	Reference number	Description	Pkg qty
1 T48-046	9-6046	Shield cup, crown	1
2 T48-047	9-6047	Shield cup, gouging	1
3 T48-045	9-6045	Shield cup	1
T48-054	9-6054	Shield cup, long	1
4 C48-025	9-6025	Tip, Air, 35 amp	5
C48-026	9-6026	Tip, Air, 70 amp	5
C48-027	9-6027	Tip, Air, 105 amp	5
C48-028	9-6028	Tip, Air, 140 amp	5
T48-034	9-6034	Tip, ArH ₂ , 70 amp	5
T48-035	9-6035	Tip, ArH ₂ , 105 amp	5
T48-036	9-6036	Tip, ArH ₂ , 140 amp	5
5 T48-037	9-6037	Tip, .110, gouging	1
T48-038	9-6038	Tip, .125, gouging	1
T48-039	9-6039	Tip, .156, gouging	1
T48-040	9-6040	Tip, .171, gouging	1
6 T48-051	9-6051	Gas distributor	1
7 T48-112	9-6112	Gas distributor, gouging	1
8 C48-048	9-6048	Electrode, Air	1
T48-050	9-6050	Electrode, ArH ₂	5
9 T48-110	9-6110	Electrode, Air, gouging	1

Maintenance items

Centricut part number	Reference number	Description	Pkg qty
T48-052	9-6052	Cooling tube	1
10 T48-815	9-5815	PCM-140 torch body, 180°	1
027055	N/A	Lubricant .25 oz. (7 ml) tube	1

OEM Thermal Dynamics[®] System PAK[®] 15XC, MERLIN[®]

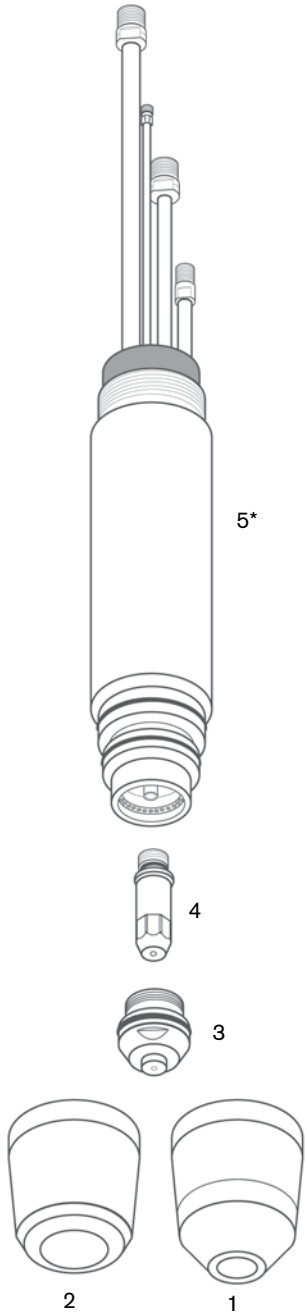

Consumables

Centricut part number	Reference number	Description	Pkg qty
1 C30-790	9-5790	Shield cup, copper	1
C30-750	9-5750	Shield cup	1
2 C30-758	9-5758	Shield cup, tip exposed	1
C30-801	9-5801	Shield cup, copper, tip exposed	1
3 C30-748	9-5748	Tip, Air, .043, 50 amp	5
C30-747	9-5747	Tip, Air, .055, 100 amp	5
C30-746	9-5746	Tip, Air, .070, 150 amp	5
C30-765	9-5765	Tip, N ₂ , .043, 50 amp	5
C30-766	9-5766	Tip, N ₂ , .052, 100 amp	5
C30-767	9-5767	Tip, N ₂ , .067, 150 amp	5
T30-753	9-5753	Tip, O ₂ , .043, 50 amp	5
T30-752	9-5752	Tip, O ₂ , .052, 100 amp	5
C30-751	9-5751	Tip, O ₂ , .070, 150 amp	5
4 C30-749	9-5749	Electrode, Air	5
C30-754	9-5754	Electrode, N ₂	5
C30-760	9-5760	Electrode, O ₂	5

Maintenance items

Centricut part number	Reference number	Description	Pkg qty
C30-M33	N/A	Liner, replacement	1
C30-M34	N/A	Gas distributor, replacement	1
C30-WRCH	N/A	Liner wrench	1
5 C30-945*	N/A	PCM-150 modular torch body, 180°	1
C30-057	N/A	O-ring torch kit – see below	1
027055	N/A	Lubricant .25 oz. (7 ml) tube	1

C30-057 O-ring torch kit includes

Centricut part number	Reference number	Description	Pkg qty
C30-035	N/A	O-ring (for gas distributor)	1
C30-037	N/A	O-ring (for liner)	1
C30-040	8-0540	O-ring (shield cup, large)	1
C30-557	8-0557	O-ring (shield cup, small)	5
C30-041	N/A	O-ring (for liner)	1

* Centricut part features a unique Hypertherm design that differs from the OEM design.

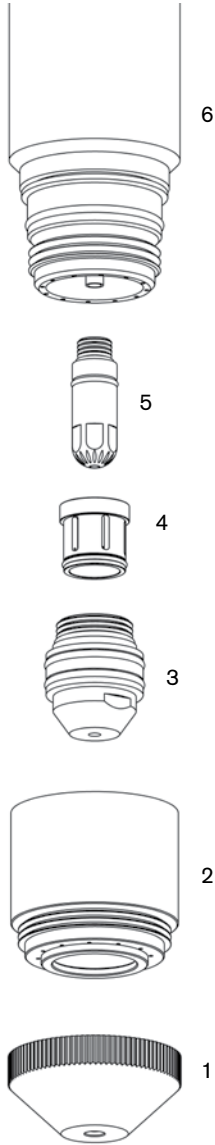

Consumables

Centricut part number	Reference number	Description	Pkg qty
1 C55-803	20-1003	Shield, 50 amp	1
C55-804	20-1004	Shield, 100 – 225 amp	1
C55-805	20-1005	Shield, 300 amp	1
C55-006	20-1006	Shield, 100 – 300 amp, underwater	1
T55-028	20-1028	Shield, 100 – 300 amp, underwater	1
2 C55-002	20-1002	Shield, cup body	1
T55-029	20-1029	Shield, cup body, underwater	1
T55-412	9-6412	Shield cup, Air, long	1
T88-744	9-6411	Shield cup, O ₂ , long	1
3 C55-030	20-1030	Tip, 50 amp	1
C55-031	20-1031	Tip, 100 amp	1
C55-032	20-1032	Tip, 150 amp	1
C55-033	20-1033	Tip, 225 amp	1
C55-034	20-1034	Tip, 300 amp	1
C55-424	9-6424	Tip, Air, 0.52, 70 amp	5
C55-425	9-6425	Tip, Air, 0.59, 105 amp	5
C55-432	9-6432	Tip, Air, 0.70, 150 amp	5
T55-419	9-6419	Tip, O ₂ , 0.52, 70 amp	5
T55-420	9-6420	Tip, O ₂ , 0.59, 105 amp	5
T55-433	9-6433	Tip, O ₂ , 0.70, 150 amp	5
T55-428	9-6428	Tip, ArH ₂ , 0.52, 70 amp	5
T55-429	9-6429	Tip, ArH ₂ , 0.59, 105 amp	5
T55-434	9-6434	Tip, ArH ₂ , 0.73, 150 amp	5
4 C55-008	20-0008	Gas distributor, 50 - 225 amp	1
T55-009	20-1009	Gas distributor, 300 amp	1
T55-416	9-6416	Gas distributor	1
5 C55-710	20-1016,	CopperLine® electrode, Air/O ₂ , 50 – 300 amp	1
	20-1010		1
	20-1021		1
C55-718	20-1015	CopperLine electrode, Air/O ₂ , 50 – 300 amp	1
	20-1018		1
T55-017	20-1017	Electrode, O ₂ , 225 amp	5
T55-023	20-1023	Electrode, N ₂ , 50 – 300 amp	5
T55-025	20-1025	Electrode, ArH ₂ , 100 – 300 amp	5
T55-1211	20-1211	Electrode, N ₂ , ArH ₂	5

Maintenance items

Centricut part number	Reference number	Description	Pkg qty
6 T55-410	9-6410	Maximizer 300 torch body	1
C55-004	N/A	O-ring	5
C55-050	N/A	O-ring	5
027055	N/A	Lubricant .25 oz. (7 ml) tube	1

OEM Thermal Dynamics[®] System TA500, 1000

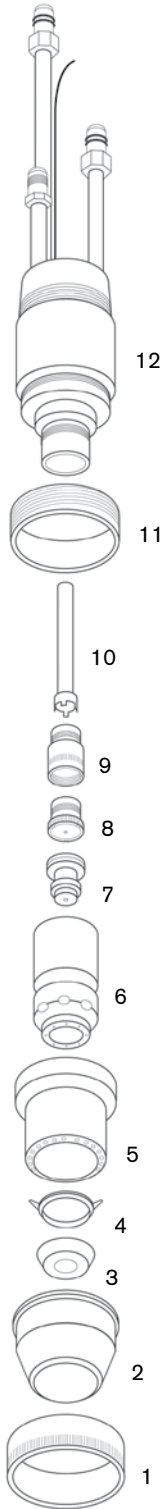

Consumables

Centricut part number	Reference number	Description	Pkg qty
1 T19-059	8-6059	Collar	1
T19-078	8-6078	Collar, underwater cutting	1
2 T19-056	8-6056	End cap	1
T19-077	8-6077	End cap, underwater cutting	1
3 C19-006	8-6006	End piece, water shield	10
C19-610	8-0610	End piece, piercing	5
T19-607	8-0607	End piece, gas shield	1
T19-029	8-6029	End piece, ArH ₂	1
T19-609	8-0609	End piece	1
6 T19-210	9-2210	Inner tip retainer	1
7 T19-041	8-6041	Tip, .081, 150 amp	1
C19-042	8-6042	Tip, .109, 250 amp	1
C19-043	8-6043	Tip, .125, 350 amp	1
C19-044	8-6044	Tip, .140, 500 amp	1
C19-045	8-6045	Tip, .172, 750 amp	1
C19-046	8-6046	Tip, .201, 1000 amp	1
T19-047	8-6047	Tip, .250, 500 amp	1
8 C19-662	9-1662	Electrode	5
T19-641	9-1641	Electrode, low amp	1
9 T19-642	9-1642	Electrode seat	1

Maintenance items

Centricut part number	Reference number	Description	Pkg qty
10 T19-640	9-1640	Coolant tube	1
11 T19-058	8-6058	Adaptor	1
12 T19-054	8-6054	M200 torch body	1
C19-563	8-0563	O-ring, end piece – end cap	5
4 T19-451	9-2451	Coolant baffle	1
5 T19-060	8-6060	Outer insulator	1
T19-720	9-3720	O-ring, end cap – outer insulator	5
T19-547	8-0547	O-ring, outer insulator – torch body	5
027055	N/A	Lubricant .25 oz. (7 ml) tube	1



**Technology products for ESAB®,
Kjellberg® and Kaliburn®**

Hypertherm®

Cut with confidence™

Hypertherm, Inc.
Hanover, NH 03755 USA
603-643-3441 Tel

Hypertherm (S) Pte Ltd.
Singapore 349567
65 6841 2489 Tel

**Hypertherm (Shanghai)
Trading Co., Ltd.**
PR China 200052
86-21 5258 3330 /1 Tel

Hypertherm Europe B.V.
4704 SE Roosendaal, Nederland
31 165 596907 Tel

HYPERTHERM BRASIL LTDA.
Guarulhos, SP - Brasil
55 11 2409 2636 Tel

www.hypertherm.com



Hypertherm and Centricut are registered trademarks of Hypertherm, Inc. and may be registered in the United States and/or other countries. All other trademarks are the properties of their respective owners.