



SilverLine® and CoolFlow™ technologies double process life!

Used together, patented SilverLine electrodes and patent-pending CoolFlow nozzles provide up to twice the process life and half the operating costs. Follow the instructions on our quick set up card. The more you cut the more you save!

Centricut product for Kaliburn (formerly InnerLogic)

ProLine® and FineLine®

Quick Set-up

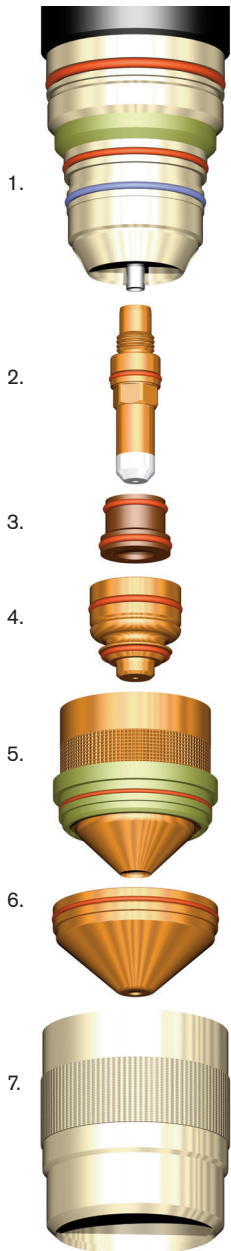
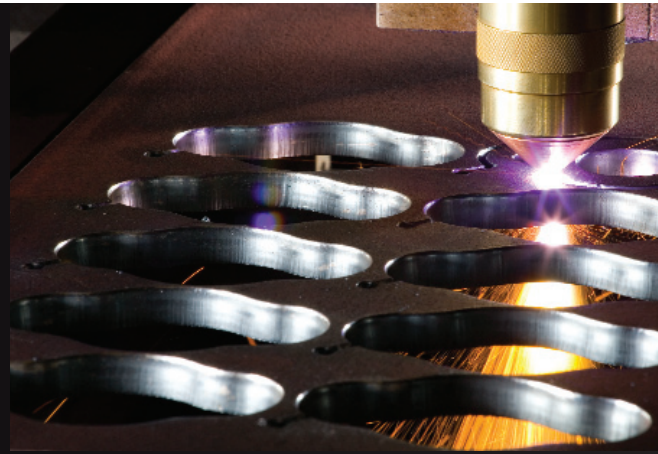

To achieve maximum SilverLine electrode life

SilverLine electrodes can be worn deeper than the OEM copper and silver foil electrodes. The 150/200/275 amp electrode can be worn to .090" (2.3 mm); the 100 amp electrodes can be worn to .070" (1.8 mm)

Purge torch: After each parts change purge the torch for at least 30 seconds to remove residual moisture.

Leak check the torch after purging to make sure all o-ring seals are working as designed.

Adjust gas flows: Plasma gas flow rate is critical. High flow will cause rapid electrode wear and hard starting. Low flow will cause uncontrolled arcing. (See parameters on back)

Adjust arc voltage: As the electrode wears, the torch will get closer to the plate. To compensate for this, increase arc voltage in 2-volt increments, up to 10 volts higher than the initial setting.

Avoid ramp-down errors: Ramp down errors can occur when rip cutting off the plate or when leading out to the dropped part as the arc stretches. These "blowouts" shorten electrode life.

Part number Reference Description

1.	I107-7000	277000	Torch body	
2.	C107-131	277131	CopperLine electrode 50/70 Amp	
	C107-1034	277134	SilverLine electrode 100 Amp	
	C107-1036	277136	SilverLine electrode 150/200 Amp	
	C107-1070	277270	SilverLine electrode 275 Amp	
	C107-142	277142	Swirl ring 50/70/100 Amp	
3.	C107-139	277139	Swirl ring 150 Amp	
	C107-259	277259	Swirl ring 200 Amp	
	C107-258	277258	Swirl ring 275 Amp	
	4.	C107-122	277122	CoolFlow nozzle 50 Amp
		C107-125	277125	CoolFlow nozzle 70 Amp
C107-127		277127	CoolFlow nozzle 100 Amp	
C107-119		277119	CoolFlow nozzle 150 Amp	
5.	C107-268	277268	CoolFlow nozzle 200 Amp	
	C107-269	277269	CoolFlow nozzle 275 Amp	
	C107-153	277153	Inner retaining cap 30/50/70 Amp	
	C107-151	277151	Inner retaining cap 100/150 Amp	
	C107-152	277152	Inner retaining cap 150 Amp	
	C107-266	277266	Inner retaining cap 200/275 Amp	
	6.	C107-115	277115	Shield cap 50 Amp
C107-150		277150	Shield cap 70 Amp	
C107-147		277147	Shield cap 100 Amp	
C107-117		277117	Shield cap 150 Amp	
C107-274		277274	Shield cap 200 Amp	
C107-263		277263	Shield cap 275 Amp	
7.		C107-154	277154	Outer cap

To achieve maximum CoolFlow nozzle life

With careful use, the CoolFlow nozzle will last 1:1 with the SilverLine electrode.

Pierce at correct height: Piercing too low causes molten metal (spatter) to hit the shield and nozzle. This is the most common cause of premature nozzle failure. Piercing too high can cause slow arc transfer and misfires. (See parameters on back)

Adjust shield flows: Shield gas protects the nozzle and shield from damage during piercing. Make sure the shield pressure is adjusted according to the cut chart and flow is adequate.

Clean shield: Periodically clean the shield to remove spatter. This will prevent double arcing, misfires, and shield and nozzle damage.

Adjust arc voltage: As parts wear, increase arc voltage in 2-volt increments to keep the shield from dragging on the plate. Damage to the shield and nozzle occurs if the torch contacts the plate during cutting.

Consumable life test

Number of ISO zone 4 cuts (< 5.15°) during 20-second life test at 200 A on 1/2-inch (13 mm) steel

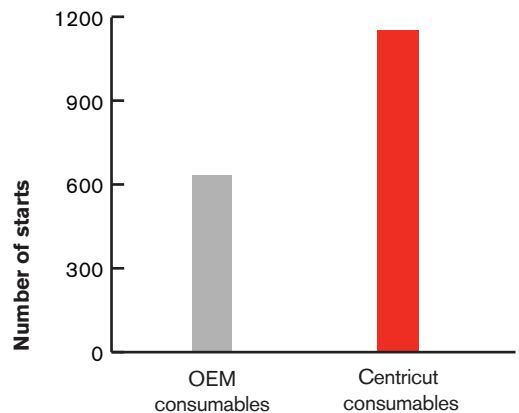

Recommended parameters for cutting mild steel with oxygen

Thickness		Amps	Pre-flow	Plasma	Shield	Voltage	Cut height		Pierce height		Speed		Motion delay
in.	mm	A	Air psi	O ₂ psi	Air psi	Volts	in.	mm	in.	mm	in/min	mm/min	msec
1/4	.250	6	100	20	80	33	0.090	2	0.125	3	150	3810	150
3/8	.375	10	100	20	80	33	0.130	3	0.175	4	100	2540	200
1/2	.5	13	100	20	80	33	0.155	4	0.200	5	65	1651	400
5/8	.625	16	100	20	80	33	0.185	5	0.200	5	47	1194	600
3/4	.750	19	100	20	80	33	0.185	5	0.200	5	35	889	900
1/4	.250	6	150*	25	75	30	0.120	3	0.200	5	165	4191	300
3/8	.375	10	150*	25	75	30	0.135	3	0.225	6	125	3175	400
1/2	.5	13	150*	25	75	30	0.140	4	0.250	6	90	2286	400
5/8	.625	16	150*	25	75	30	0.150	4	0.275	7	70	1778	600
3/4	.750	19	150**	25	75	45	0.140	4	0.300	8	55	1397	900
1/4	.250	6	200	20	80	58	0.125	3	0.250	6	230	5842	300
3/8	.375	10	200	20	80	58	0.125	3	0.250	6	140	3556	300
1/2	.5	13	200	20	80	58	0.125	3	0.250	6	120	3048	500
5/8	.625	16	200	20	80	58	0.130	3	0.250	6	100	2540	500
3/4	.750	19	200	20	80	58	0.150	4	0.300	8	75	1905	700
1	1	25	200	20	80	58	0.175	4	0.300	8	50	1270	1000
3/4	.750	19	275	20	90	70	0.120	3	0.300	8	90	2286	700
1	1	25	275	20	90	70	0.160	4	0.300	8	65	1651	900
1-1/4	1.25	32	275	20	90	70	0.175	5	0.350	9	45	1143	1200
1-1/2 [†]	1.5	39	275	20	90	70	0.235	6	0.350	9	25	635	400
1-3/4 [†]	1.75	45	275	20	90	70	0.290	7	0.350	9	20	508	400
2 [†]	2	51	275	20	90	70	0.350	9	0.350	9	15	380	400

* Use cap C107-151

** Use cap C107-152

[†] Edge start or moving pierce recommended

SilverLine electrode technology

SilverLine electrodes involve welding a solid silver front-end to a copper electrode base and inserting a hafnium pin into the silver. Silver front-end electrodes offer several advantages over traditional copper designs:

- 1) The hafnium-silver bond is stronger, allowing a deeper pit depth in the hafnium as the electrode is used.
- 2) The heat transfer properties of silver and silver oxides are superior which improves heat dissipation during use and slows the rate of hafnium wear.

Both of these benefits combine to prolong electrode life and lower the cost of cutting. See other side for test results.

CoolFlow nozzle technology

CoolFlow nozzles are designed for long service life and better heat transfer, using state-of-the-art computer modeling to analyze the cooling water flow and heat transfer from the plasma arc.

- 1) Solid head – improves conduction cooling and excellent shield alignment.
- 2) Angled seal – the o-ring is positioned out of the hot zone for improved sealing reliability and robustness to leaks.
- 3) Curved flow path – the optimized cooling groove is designed to minimize coolant stagnation and maximize convective cooling to keep the nozzle and seal cool.
- 4) Back seal – extra o-ring at rear face of nozzle protects against leaks.

Centricut SilverLine electrode

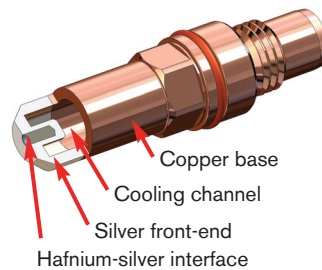

OEM electrode

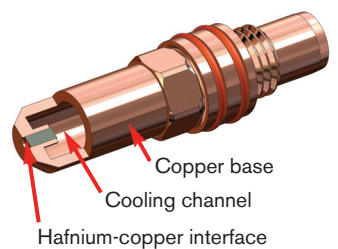

Part type	Centricut maximum pit depth	OEM maximum pit depth
150/200/275 A electrode	.090" (2.3 mm)	.050" (1.3 mm)
100 A electrode	.070" (1.8 mm)	.050" (1.3 mm)

Centricut CoolFlow nozzle

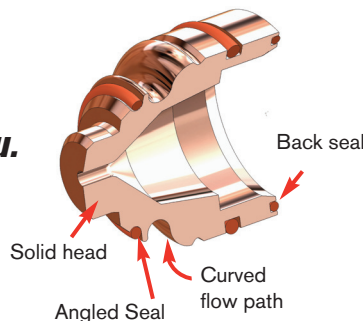

OEM nozzle

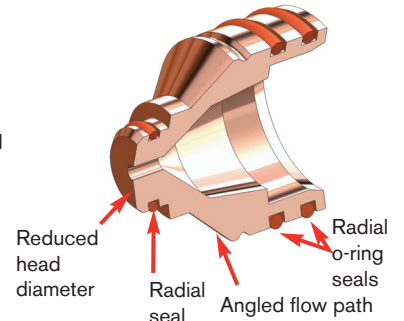

Contact your Hypertherm distributor or call 1-800-752-7623 for the location nearest to you.



Hypertherm, Inc.
Hanover, NH 03755 USA
603-643-3441 Tel

Hypertherm (S) Pte Ltd.
Singapore 349567
65 6 841 2489 Tel

Hypertherm (Shanghai) Trading Co., Ltd.
PR China 200052
86-21 5258 3330 /1 Tel

Hypertherm Europe B.V.
4704 SE Roosendaal, Nederland
31 165 596907 Tel

HYPERTHERM BRASIL LTDA.
Guarulhos, SP - Brasil
55 11 6409 2636 Tel

www.hypertherm.com

Centricut, Hypertherm, SilverLine and CoolFlow are trademarks of Hypertherm, Inc., and may be registered in the United States and/or other countries. All other trademarks are the property of their respective owners. Hypertherm is in no way affiliated with InnerLogic or Kaliburn.

© 5/08 Hypertherm, Inc. 880640